

PROJECT: \_\_\_\_\_ CATALOG # \_\_\_\_\_ NOTES: \_\_\_\_\_ FIXTURE SCHEDULE: \_\_\_\_\_

# FLOOD CLASS I DIVISION 1 | HL-AR-D1 SERIES

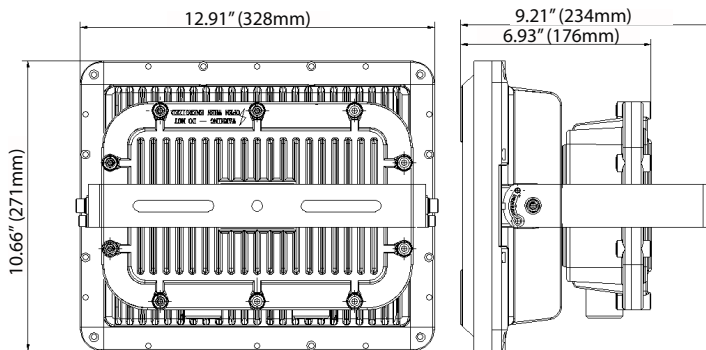

A rock star in rugged performance, the **Class I, Division 1 HL-AR-D1 SERIES** delivers high-quality illumination that meets the rigorous demands of **harsh and hazardous** environments, including oil rigs and petroleum refineries. Consuming 50% less energy than traditional HID fixtures, the marine-grade HL-AR-D1 flood light is built for maximum durability and reliability in operating temperatures of up to 60°C. The fixture can be ceiling or wall mounted to address a variety of area lighting needs. A 2-3/8" tennon adaptor is also available.



### CLASSIFICATIONS & RATINGS:

- Class I, Division 1, Groups C, D
- Class I, Division 2, Groups A, B, C, D
- Class II, Division 2, Groups F, G
- Marine Grade
- CSA C22.2, No. 250.0, No. 250.13, No. 137-M1981, No. 30-M1986 No. 25-1966
- See table on page 2 for Temperature Code and ambient temperature ranges

### CONSTRUCTION:

- Die cast ADC12 aluminum housing
- Tempered Glass, 19mm
- Polyester powder coat finish

### MOUNTING:

- Standard trunnion swivel mounting option allows for 0° - 180° adjustability
- 2-3/8" tennon adaptor available

### ELECTRICAL:

- 9,600 lm to 18,245 lm
- 120-277V or 347-480V available
- Power Factor: > 0.90

### WARRANTY:

5-year standard warranty\* (further details available at [www.maxlite.com/warranties](http://www.maxlite.com/warranties))

\*Product may be eligible for a warranty extension to 10 years, for an additional fee. Contact MaxLite for details.

MODEL SELECTION Typical order example: HL-AR80UW-50G-D1										
HL	-	AR			W	-	50	G	-	D1
FAMILY	-	SUB FAMILY	NOMINAL WATTAGE, EQUIVALENCY	VOLTAGE	DISTRIBUTION	-	CCT	FINISH	-	CLASSIFICATION
HL= Hazardous Location	-	AR= Flood Light	<b>80=</b> 80W, 175W MH Equivalency <b>100=</b> 100W, 400W MH Equivalency <b>150=</b> 150W, 400W PSMH Equivalency	<b>U=</b> 120-277V <b>H=</b> 200-480V	<b>W=</b> 120°, wide distribution	-	<b>50=</b> 5000K <sup>1</sup>	<b>G=</b> Gray, std.	-	<b>D1=</b> CID1 Explosion Proof Rated

**Notes:**  
1. Custom CCTs available. Please contact your MaxLite representative for lead times and quantities.

PROJECT: \_\_\_\_\_ CATALOG # \_\_\_\_\_ NOTES: \_\_\_\_\_ FIXTURE SCHEDULE: \_\_\_\_\_

# FLOOD CLASS I DIVISION 1 | HL-AR-D1 SERIES

**ACCESSORIES:**

ORDER CODE	MODEL	DESCRIPTION	ACCESSORIES IMAGE
1409664	HL-ARTB	2-3/8" Tennon Adaptor	

**SPECIFICATIONS:**

		HL-AR80-D1	HL-AR100-D1	HL-AR150-D1
ITEM	SPECIFICATION	DETAILS		
<b>GENERAL PERFORMANCE</b>	Input Power (W)	80	100	150
	Lumens Delivered (lm)	9,600	12,000	18,245
	Efficacy (lm/W)	120		
	CRI	> 70		
	Lumen Maintenance (L70, TM-21 @ 25°C)	≥100,000 hours		
	Color Temperature	5000K standard, custom CCTs available		
	Spacing Criteria	Available upon request		
<b>ELECTRICAL</b>	Power Factor	≥ 0.90		
	Input Voltage	120-277V standard, 347-480V available		
<b>PHYSICAL</b>	Housing	Die cast ADC12 Aluminum		
	Lens	Tempered Glass, 19mm		
	Weight	33 lbs (15 kg)		
	Humidity	10% - 90% RH, non condensing		
	Operating Temperature	-40°C - 60°C (-40°F - 140°F)		
	Temperature Rating	T6 Rating		
<b>CERTIFICATION</b>	Certification	DLC Premium, UL844, UL1598, UL1598A, FCC, LM79, LM80		
	Environment	IP66		
	Material Usage	RoHS compliant; no mercury		
	Warranty	5-year standard warranty*		

**ORDERING:**

ORDER CODE	MODEL	NOMINAL WATTAGE	INPUT VOLTAGE	CCT
1409541	HL-AR80UW-50G-D1	80W	120-277V	5000K
1409542	HL-AR80HW-50G-D1		347-480V	
1409543	HL-AR100UW-50G-D1	100W	120-277V	
1409593	HL-AR100HW-50G-D1		347-480V	
1409545	HL-AR150UW-50G-D1	150W	120-277V	
1409546	HL-AR150HW-50G-D1		347-480V	

\*Please contact your MaxLite representative to order products that don't have order codes listed here.